



# SUBMERSIBLE DEWATERING PUMPS

ENG 50 HZ

**PUMPEX**





# WELCOME TO PUMPEX, ONE OF THE WORLD'S LEADING MANUFACTURERS OF SUBMERSIBLE DEWATERING PUMPS.

## **Dedicated Partner**

Pumpex is a complete equipment supplier for professional dewatering applications. With over 40 years of experience from the industry, we know what works in the field. Our high quality products and engaged know-how provides a reliable support for our partners and customers. Our pumps combine high reliability with excellent serviceability, which results in unrivalled operating economy.

## **For professional use**

Submersible dewatering pumps are used in a wide range of applications when water need to be moved, at construction sites, for irrigation, in ship yards, by utility companies, in rescue ships, by fire brigades, in mines and quarries, in general industries, by power companies etc. Pumpex wide range of dewatering pumps provides a suitable choice for most of these applications.

## **Solid Quality**

At Pumpex, quality means:

- Robust design
- High grade materials
- Trouble-free operation
- Ease of service

Construction and mining applications, as well as industrial, municipal and agricultural needs, have influenced our Swedish engineers in the development, design and production of Pumpex professional dewatering pumps. Maintained efficiency is a key factor to operating economy, which is why Pumpex pumps use high-efficiency motors and hydraulics.

## **Strong Traditions**

Since our start in the late 1960's, we have developed our products to meet the increasing demands of an international market. Our customers today can be found in more than 70 countries all over the world.



# WATER DESERVES THE HARD-HEADED APPROACH

## **Dedicated Dewatering**

All our authorized distributors are trained in pump application pump selection, and they are supported by our engineers and our state-of-the-art Pumpex pump selection software, PUMPEXplorer®.

## **Company**

Pumpex is a stable AAA rated (Dun and Bradstreet) company belonging to the Cardo group which has about 10 billion SEK turnover. Cardo is a public company listed on the OMX Nordic Exchange.

## **Contact**

Pumpex products are sold, rented and serviced by professional distributors all around the globe. Together with our distributors, we work hard to meet the demands of our end-users, for whom the availability of products and spares is vital.



# PUMPEX SUBMERSIBLE DRAINAGE PUMP

## P 401 - P 3001, PX 12 - PX 30, PC 1001 - PC 3001

**Pumpex submersible drainage pump P 401 - P 3001, PX 12 - PX 30, PC 1001 - PC 3001** are suitable for pumping water and dirty water mixed with soil. When delivered to a site you can start using them right away. The low weight and compact design vouches for convenient transport, handling and installation. Just plug and pump!

### **No suction lift limitations**

Pumpex drainage pumps are submersible to 20 m depth and have no suction lift limitations. This is superior to any self-priming system due to the fact that the pump is installed submerged in the pit. The pump does not need to be moved with varying water levels and it is designed to run dry in case the water level drops too low. There are no suction hoses, and no vacuum priming issues.

### **High reliability**

Double mechanical shaft seal in oil bath (silicon carbide on silicon carbide in the primary seal) for long life. Rigid stainless steel shaft with lower double angular contact ball bearings for vibration-free operation. Large strainer area minimizes the risk of clogging.

### **Trouble free and safe handling**

Pumpex drainage pumps are equipped for immediate use. The low weight, encapsulated motor and no external moving parts makes installation and operation easy and safe.

### **High wear resistance**

Impeller in high chrome alloy steel with a hardness of 60 Rc.

Adjustable wear parts covered with oil resistant nitrile rubber to secure a long lifetime with high efficiency. For extreme conditions choose Pumpex exclusive Enduro Lining™ polyurethane coated wear parts.

### **Plug-in start with motor protection**

Built-in contactor, capacitor (Single Phase) and thermal protectors in the stator windings protects the motor and features an automatic restart function.

### **High flexibility**

The pump can operate in every position, vertical, horizontal or even upside down. The pump can easily be converted between standard, high head or high volume versions.

### **Corrosion resistant**

Outer casing, rotor shaft and hardware are made of stainless steel. Casted parts are made in lightweight aluminium alloy, externally with a protective coating.

### **Can run dry**

Double outer casing and good heat convection make it possible to run the pump dry or in a snore condition.





## Easy service and maintenance

Common philosophy through the complete range with modular design and interchangeable spare parts. (For example identical shaft seals for P 601-P 801, P 1001-P 3001, PX 12-PX 22.)

- Easy access to separate sealed electrical junction box.
- Easy to adjust or replace hydraulic wear parts.

## Environmentally safe

The oil housing is filled with environmentally safe white oil. Non toxic coatings are used.

## Environmental Product Declaration EPD®

Certified Environmental Product Declaration, EPD®, is a new system to present a products environmental impact during its entire life cycle. The environmental product declarations are based on product specific life cycle analyses, conducted in accordance with the ISO14040-series.



Reduce the Environmental Impact (LCA):

- 1) Select the right size pump for the application.
- 2) Use at optimum efficiency.
- 3) Keep a high degree of efficiency by replacing wear parts.



## PUMPEX P 401

<b>Pump Type</b>	<b>W, 1-phase</b>
Motor rating $P_2$	0.48 kW
Max. power input $P_1$	0.59 kW
Voltage (V)	230
Full load (A)	2.9
Speed	2690 rpm
Motor protection	built in
Electric cable	10 m
Strainer passage	6 mm
Discharge connection	Hose 2"
	Option: G2"
Weight (excl. cable)	9.5 kg

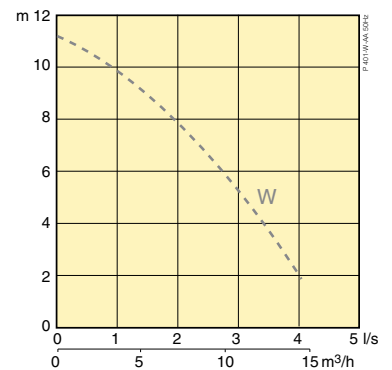
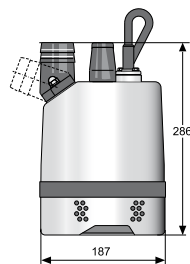

## PUMPEX P 601

<b>Pump Type</b>	<b>N / NA*</b>	<b>W / WA*</b>
	<b>3-phase</b>	<b>1-phase</b>
Motor rating $P_2$	1.0 kW	0.9 kW
Max. power input $P_1$	1.3 kW	1.2 kW
Voltage (V)	230/400/500	110/230
Full load (A)	4.0 / 2.3 / 1.9	10.4 / 5.2
Speed	2800 rpm	2750 rpm
Motor protection	built in	
Electric cable	20 m	
Strainer passage	6.5 x 15.5 mm	
Discharge connection	Hose 2"	
	Option: 1½", 2½", 3", G2", G2½", G3"	
Weight (excl. cable)	16 kg	

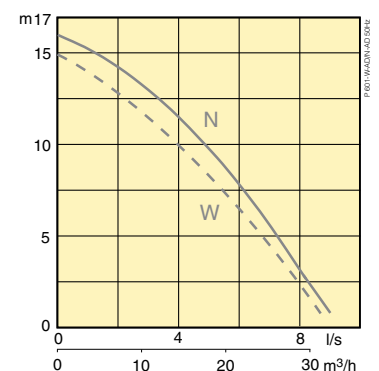
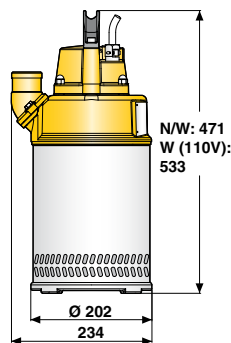

*\*) Built in float switch available as option.*

## PUMPEX P 801

Pump Type	N / NA* 3-phase	W / WA* 1-phase
Motor rating $P_2$	1.4 kW	1.4 kW
Max. power input $P_1$	1.8 kW	1.9 kW
Voltage (V)	230/400/500	230
Full load (A)	5.0 / 2.9 / 2.3	8.1
Speed	2800 rpm	2800 rpm
Motor protection	built in	
Electric cable	20 m	
Strainer passage	6.5 x 15.5 mm	
Discharge connection	Hose 2" Option: 1½", 2½", 3", G2", G2½", G3"	
Weight (excl. cable)	16.5 kg (N), 18 kg (W)	

\*) Built in float switch available as option.

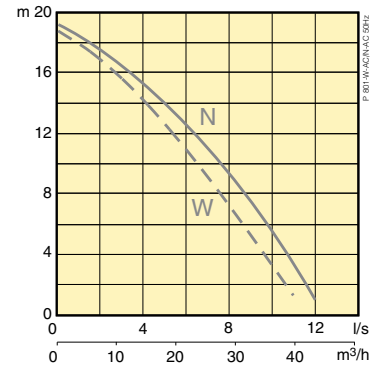
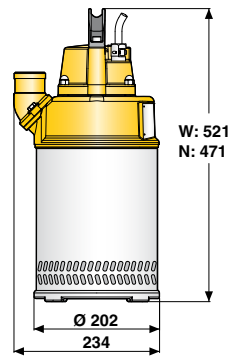

## PUMPEX P 1001

Pump Type	N / H 3-phase
Motor rating $P_2$	2.3 kW
Max. power input $P_1$	2.8 kW
Voltage (V)	230 / 400 / 500 / 1000
Full load (A)	8.4 / 4.8 / 3.8 / 1.9
Speed	2870 rpm
Motor protection	built in
Electric cable	20 m
Strainer passage	7.5 x 16.5 mm
Discharge connection	Hose 3" Option: 2½", 4", G2½", G3", G4"
Weight (excl. cable)	29 kg

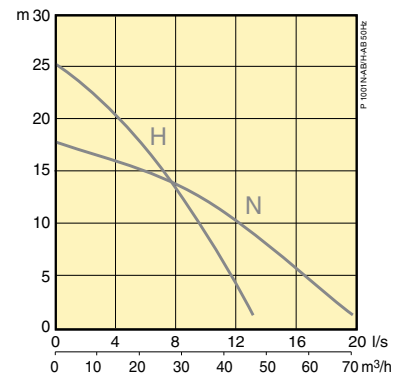
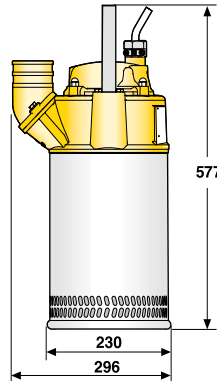

## PUMPEX P 1501

Pump Type	N, 3-phase
Motor rating $P_2$	3.9 kW
Max. power input $P_1$	4.7 kW
Voltage (V)	230 / 400 / 500 / 1000
Full load (A)	14.1 / 8.1 / 6.5 / 3.2
Speed	2870 rpm
Motor protection	built in
Electric cable	20 m
Strainer passage	7.5 x 16.5 mm
Discharge connection	Hose 3" Option: 2½", 4", G2½", G3", G4"
Weight (excl. cable)	31 kg

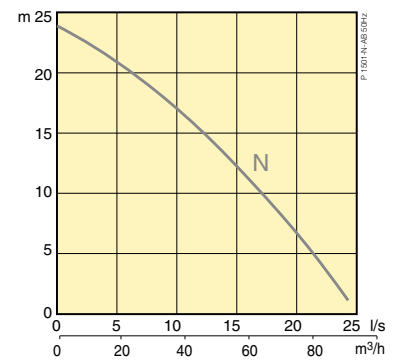
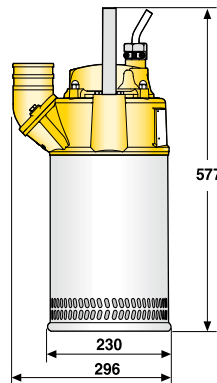

## PUMPEX P 2001

Pump Type	N / H / V 3-phase
Motor rating $P_2$	5.8 kW
Max. power input $P_1$	6.8 kW
Voltage (V)	230 / 400 / 500 / 1000
Full load (A)	21 / 12 / 9.2 / 4.6
Speed	2850 rpm
Motor protection	built in
Electric cable	20 m
Strainer passage	7.5 x 16.5 mm
Discharge connection	Hose 3" (H), 4" (N), 6" (V) Option: G3", G4", G6"
Weight (excl. cable)	50 kg

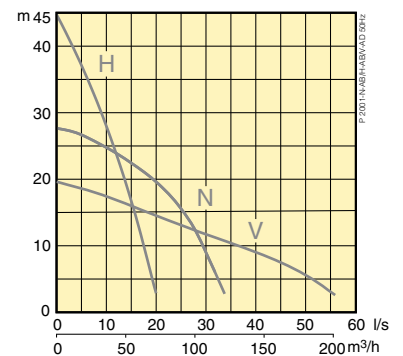
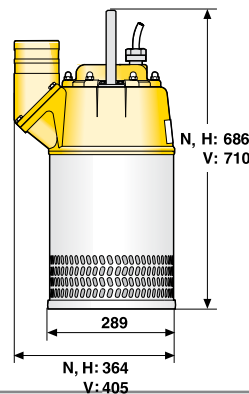

## PUMPEX P 3001

Pump Type	N / H / V 3-phase
Motor rating $P_2$	9.4 kW
Max. power input $P_1$	10.8 kW
Voltage (V)	230 / 400 / 500 / 1000
Full load (A)	31 / 18 / 14 / 7
Speed	2850 rpm
Motor protection	built in
Electric cable	20 m
Strainer passage	7.5 x 16.5 mm
Discharge connection	Hose 3" (H), 4" (N), 6" (V) Option: G3", G4", G6"
Weight (excl. cable)	70 kg (N, V), 75 kg (H)

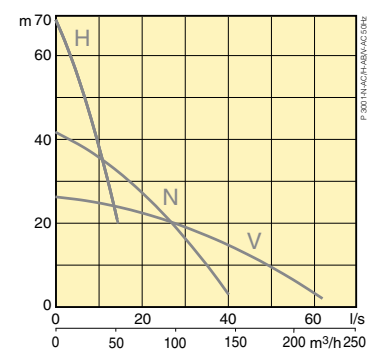
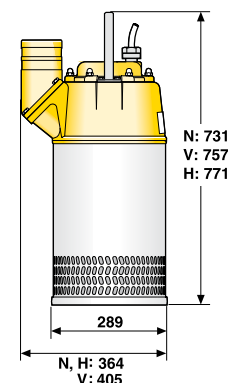

## PUMPEX PX 12

### Pump Type

**N / H**  
**3-phase**

Motor rating $P_2$	21 kW
Max. power input $P_1$	24 kW
Voltage (V)	230 / 400 / 500 / 1000
Full load (A)	68 / 39 / 31 / 16
Speed	2930 rpm
Motor protection	built in
Electric cable	20 m
Strainer passage	8 x 34 mm
Discharge connection	Hose 4" (H), 6" (N) Option: 8", G4", G6", G8"
Weight (excl. cable)	155 kg

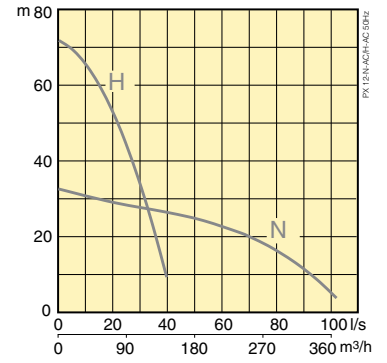
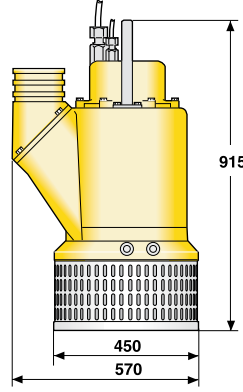

## PUMPEX PX 22

### Pump Type

**N / H**  
**3-phase**

Motor rating $P_2$	35 kW
Max. power input $P_1$	38 kW
Voltage (V)	230 / 400 / 500 / 1000
Full load (A)	108 / 62 / 50 / 25
Speed	2930 rpm
Motor protection	thermal overload sensors
Electric cable	20 m
Strainer passage	8 x 34 mm
Discharge connection	Hose 4" (H), 8" (N) Option: 6", G4", G6", G8"
Weight (excl. cable)	270 kg

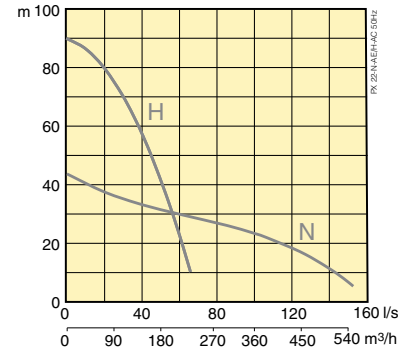
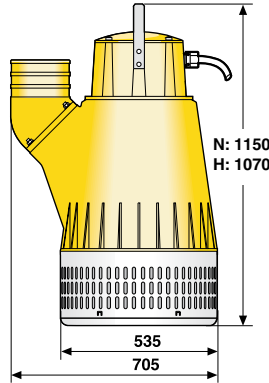

## PUMPEX PX 30

### Pump Type

**N / H**  
**3-phase**

Motor rating $P_2$	56 kW
Max. power input $P_1$	61 kW
Voltage (V)	230 / 400 / 500 / 1000
Full load (A)	184 / 106 / 84 / 42
Speed	1450 rpm
Motor protection	thermal overload sensors
Electric cable	20 m
Strainer passage	12 x 60 mm
Discharge connection	Hose 6" (H), 10" (N) Option: 8", G6", G8"
Weight (excl. cable)	525 kg

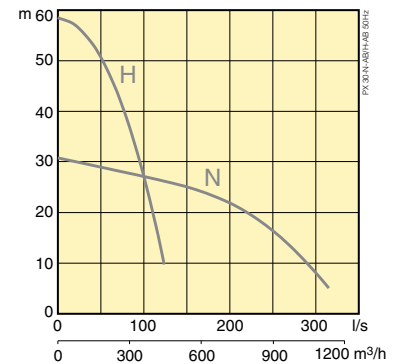
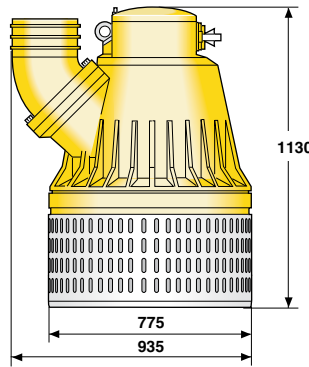

## PUMPEX PC 1001

### Pump Type

**N / H**  
**3-phase**

Motor rating $P_2$	2.3 kW
Max. power input $P_1$	2.8 kW
Voltage (V)	230 / 400 / 500
Full load (A)	8.4 / 4.8 / 3.8
Speed	2870 rpm
Motor protection	built in
Electric cable	20 m
Strainer passage	7.5 x 16.5 mm
Discharge connection	G 3"
Weight (excl. cable)	29 kg

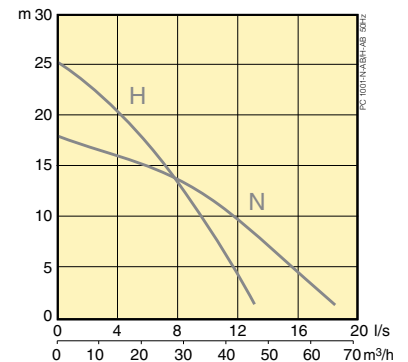
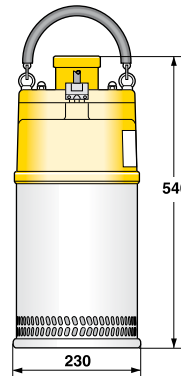

## PUMPEX PC 1301

### Pump Type

**N / H**  
**3-phase**

Motor rating $P_2$	3.0 kW
Max. power input $P_1$	3.8 kW
Voltage (V)	230 / 400 / 500
Full load (A)	12.7 / 7.3 / 5.5
Speed	2850 rpm
Motor protection	built in
Electric cable	20 m
Strainer passage	8 x 33 mm
Discharge connection	Hose 2" (H), 3" (N) Option: G2", G3"
Weight (excl. cable)	31 kg

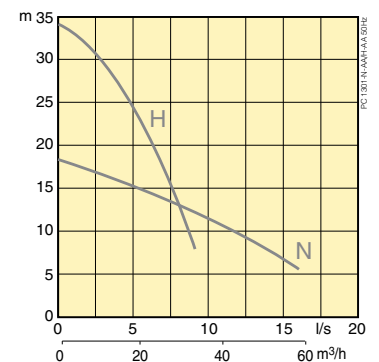
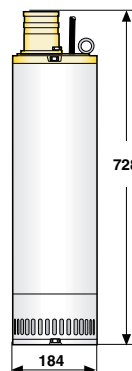

## PUMPEX PC 1501

<b>Pump Type</b>	<b>N, 3-phase</b>
Motor rating $P_2$	3.9 kW
Max. power input $P_1$	4.7 kW
Voltage (V)	230 / 400 / 500
Full load (A)	14.1 / 8.1 / 6.5
Speed	2870 rpm
Motor protection	built in
Electric cable	20 m
Strainer passage	7.5 x 16.5 mm
Discharge connection	G3"
Weight (excl. cable)	31 kg

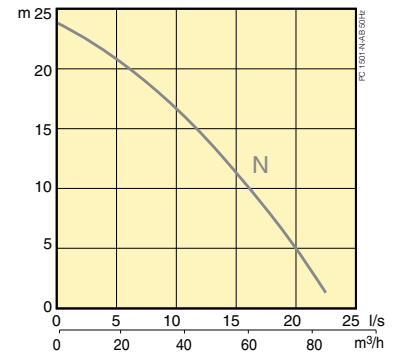
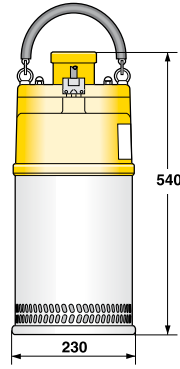

## PUMPEX PC 2001

<b>Pump Type</b>	<b>N / H / V</b> <b>3-phase</b>
Motor rating $P_2$	5.8 kW
Max. power input $P_1$	6.8 kW
Voltage (V)	230 / 400 / 500
Full load (A)	21 / 12 / 9.2
Speed	2850 rpm
Motor protection	built in
Electric cable	20 m
Strainer passage	7.5 x 16.5 mm
Discharge connection	G3" (H), G4" (N,V)
Weight (excl. cable)	50 kg

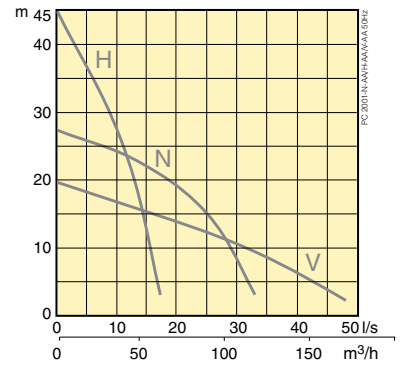
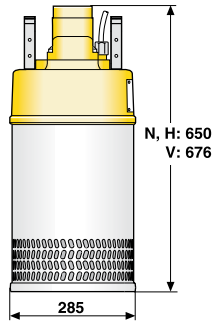

## PUMPEX PC 3001

<b>Type</b>	<b>N / V</b> <b>3-phase</b>
Motor rating $P_2$	9.4 kW
Max. power input $P_1$	10.8 kW
Voltage (V)	230 / 400 / 500
Full load (A)	31 / 18 / 14
Speed	2850 rpm
Motor protection	built in
Electric cable	20 m
Strainer passage	7.5 x 16.5 mm
Discharge connection	G4"
Option: G3"	
Weight (excl. cable)	70 kg

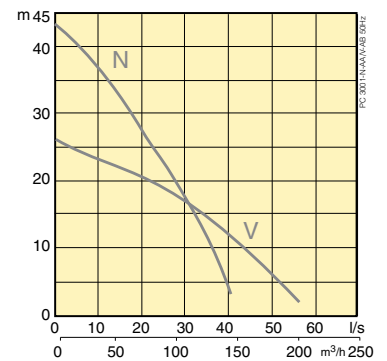
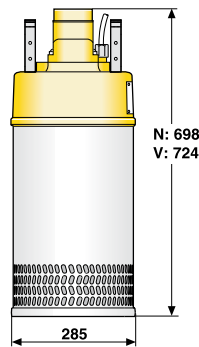

## Light Duty Pump

### PUMPEX GA 200

<b>Pump Type</b>	<b>1-phase</b>
Motor rating $P_2$	0.16 kW
Voltage (V)	230
Full load (A)	1.6
Speed	2900 rpm
Motor protection	built in
Electric cable	10 m
Discharge connection	G 1 1/4"
Weight (excl. cable)	3.8 kg

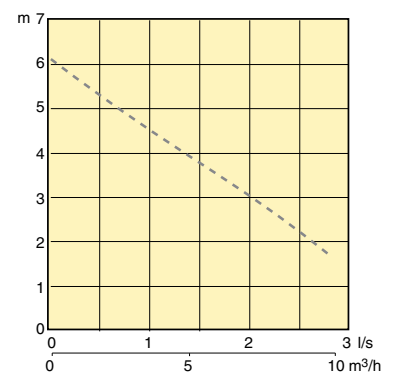
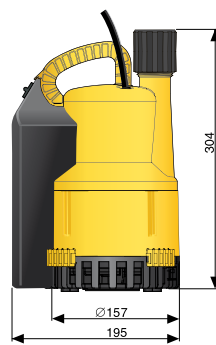



# PUMPEX LIGHTWEIGHT SLUDGE PUMPS SP 10 - SP 80 FOR HEAVY DUTY

Pumpex submersible sludge pump SP 10 - SP 80 are excellent for pumping sludge and water mixed with solid. They have a slim design and low weight, which makes them easy to move and easy to handle. Once a SP pump is installed it can run without risk of overheating the motor or sludge clogging.

## Easy to move

Casted motor parts are made in lightweight aluminium alloy so the pump can easily be moved to the right location.

## High wear resistance

Impeller and pump housing are made in wear resistant ductile iron for maximum wear resistance and durability, extending the life of the pump.

For extreme conditions choose Pumpex stainless steel vortex impellers.

## Solids handling capability

The SP sludge pumps are fitted with free flow vortex impeller and pump housing that provides great flows without clogging.

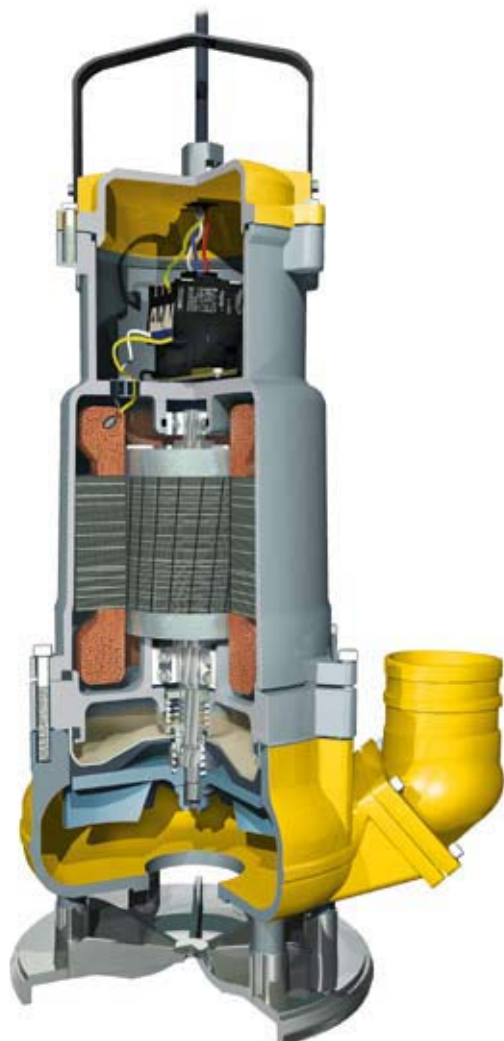

## Trouble free and safe handling

Pumpex pumps are equipped for immediate use. The slim design, encapsulated motor and no external moving parts makes installation and operation easy and safe.

## Plug-in start with motor protection

Built-in contactor, capacitor (Single Phase) and thermal protectors in the stator windings protects the motor and features an automatic restart function.

## High reliability

Double mechanical shaft seal in oil bath (silicon carbide on silicon carbide in the primary seal) for long life even under the most demanding running conditions.

Rigid stainless steel shaft with lower double angular contact ball bearings for vibration-free operation and long pump life.

## High flexibility

The pump can operate in any position, vertical or horizontal.

The impellers are available in different sizes to meet your specific pumping requirements.

## Non overloading performance

Flexible curve selection offers (blue) curve when you expect dry or snore running conditions. When half the motor or more (pump can operate lying down) is submersed you may choose the maximum impeller diameter (red curve).

## Easy service and maintenance

Common philosophy through the complete range with modular design and interchangeable spare parts. (For example identical shaft seals and shaft end on SP20 to SP80)

- Easy access to separate sealed electrical junction box.
- Easy to replace hydraulic parts such as impeller and volute.

## Environmentally safe

The oil housing is filled with environmentally safe white oil. Non toxic coatings are used.

## PUMPEX SP 10 W

<b>Pump Type</b>	<b>SP 10 W / WA*-2104</b> <b>SP 10 W / WA*-2114</b>
Motor rating $P_2$	0.9 kW, 1~
Max. power input $P_1$	1.2 kW
Voltage (V)	230
Full load (A)	5.1
Speed	2850 rpm
Motor protection	built in
Electric cable	20 m
Free passage	Ø 40 mm
Discharge connection	Hose 2"
	Option: 2½", 3", G2", G2½", G3"
Weight (excl. cable)	18 kg

\*) Built in float switch available as option.

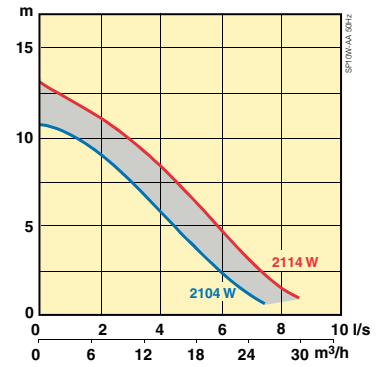
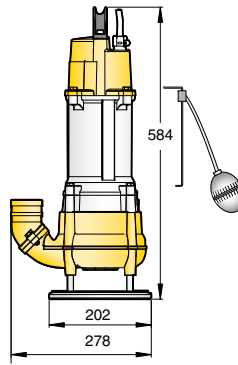

## PUMPEX SP 10

<b>Pump Type</b>	<b>SP 10/A*-2104</b> <b>SP 10/A*-2114</b>
Motor rating $P_2$	0.9 kW, 3~
Max. power input $P_1$	1.2 kW
Voltage (V)	230 / 400 / 500
Full load (A)	3.3 / 1.9 / 1.5
Speed	2850 rpm
Motor protection	built in
Electric cable	20 m
Free passage	Ø 40 mm
Discharge connection	Hose 2"
	Option: 2½", 3", G2", G2½", G3"
Weight (excl. cable)	18 kg

\*) Built in float switch available as option, excl. 500V.

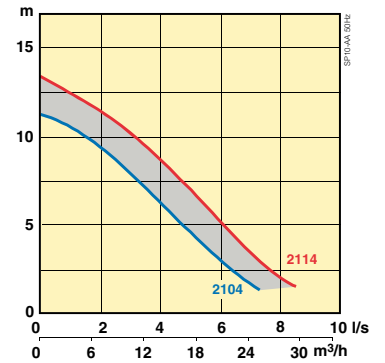
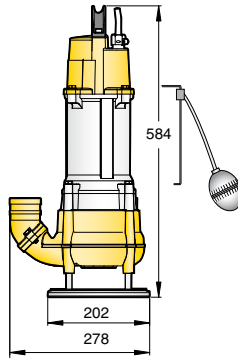

## PUMPEX SP 14

<b>Pump Type</b>	<b>SP 14/A*-2114</b> <b>SP 14/A*-2126</b>
Motor rating $P_2$	1.3 kW, 3~
Max. power input $P_1$	1.6 kW
Voltage (V)	230 / 400 / 500
Full load (A)	4.5 / 2.6 / 2.1
Speed	2850 rpm
Motor protection	built in
Electric cable	20 m
Free passage	Ø 40 mm
Discharge connection	Hose 3"
	Option: 2", 2½", G2", G2½", G3"
Weight (excl. cable)	18 kg

\*) Built in float switch available as option, excl. 500V.

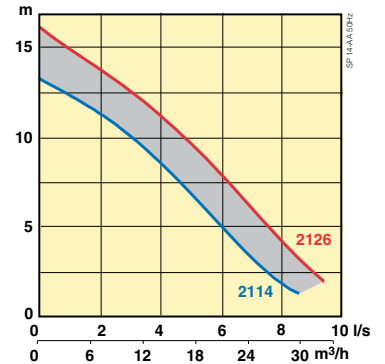
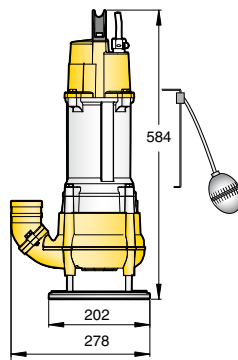

## PUMPEX SP 20

<b>Pump Type</b>	<b>SP 20/A*-2124</b> <b>SP 20/A*-2140</b>
Motor rating $P_2$	2.0 kW, 3~
Max. power input $P_1$	2.4 kW
Voltage (V)	230 / 400 / 500
Full load (A)	7.3 / 4.2 / 3.4
Speed	2870 rpm
Motor protection	built in
Electric cable	20 m
Free passage	Ø 60 mm
Discharge connection	Hose 3"
	Option: 2½", 4", G2½", G3", G4"
Weight (excl. cable)	29 kg

\*) Built in float switch available as option, excl. 500V.

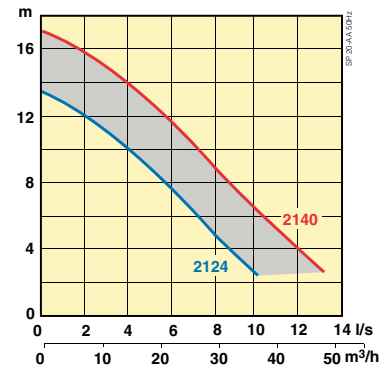
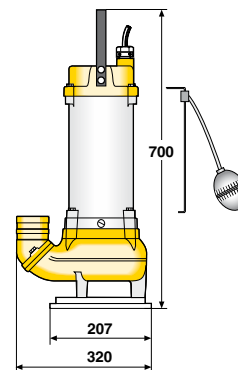

## PUMPEX SP 30

<b>Pump Type</b>	<b>SP 30/A*-2140</b> <b>SP 30/A*-2160</b>
Motor rating $P_2$	3.3 kW, 3~
Max. power input $P_1$	3.9 kW
Voltage (V)	230 / 400 / 500
Full load (A)	12 / 6.9 / 5.5
Speed	2870 rpm
Motor protection	built in
Electric cable	20 m
Free passage	Ø 60 mm
Discharge connection	Hose 3"
	Option: 2½", 4", G2½", G3", G4"
Weight (excl. cable)	31 kg

\*) Built in float switch available as option, excl. 500V.

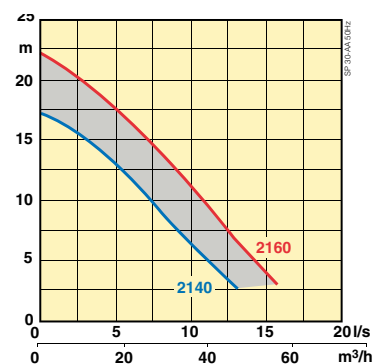
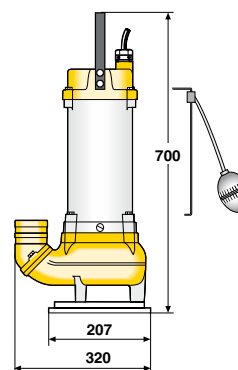

# PUMPEX SP 50

<b>Pump Type</b>	<b>SP 50/A*-2160</b> <b>SP 50/A*-2175</b>
Motor rating $P_2$	5.2 kW, 3~
Max. power input $P_1$	6.2 kW
Voltage (V)	230 / 400 / 500
Full load (A)	19.1 / 11 / 8.4
Speed	2850 rpm
Motor protection	built in
Electric cable	20 m
Free passage	Ø 65 mm
Discharge connection	Hose 4"
	Option: 3", G3", G4"
Weight (excl. cable)	54 kg

\*) Built in float switch available as option, excl. 500V.

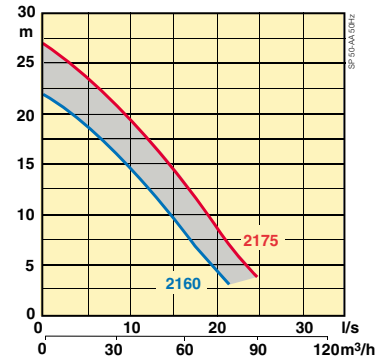
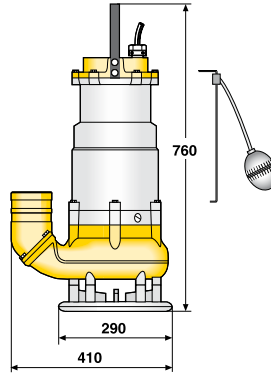

# PUMPEX SP 80

<b>Pump Type</b>	<b>SP 80/A*-2175</b> <b>SP 80/A*-2196</b>
Motor rating $P_2$	8.0 kW, 3~
Max. power input $P_1$	9.4 kW
Voltage (V)	230 / 400 / 500
Full load (A)	27.8 / 16 / 12.2
Speed	2850 rpm
Motor protection	built in
Electric cable	20 m
Free passage	Ø 65 mm
Discharge connection	Hose 4"
	Option: 3", G3", G4"
Weight (excl. cable)	67 kg

\*) Built in float switch available as option, excl. 500V.

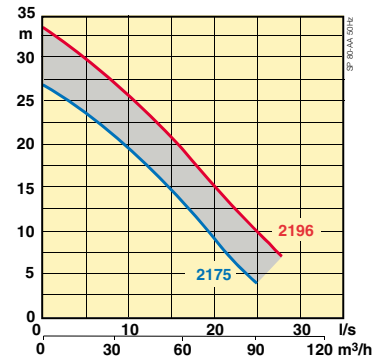
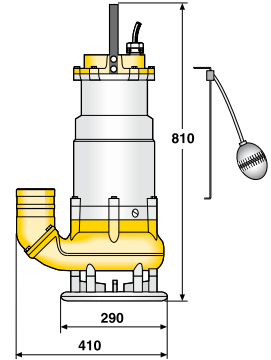

## Light Duty Pump

# PUMPEX KV 54-56

Pump Type	KV 54 W / WA*	KV 55 W / WA*	KV 56 / A*
Motor rating $P_2$	0.7 kW, 1~	1.5 kW, 1~	1.8 kW, 3~
Max. power input $P_1$	1.1 kW	2.1 kW	2.4 kW
Voltage (V)	230	230	400
Full load (A)	4.8 A	9.0	4.1
Speed	2900 rpm	2900 rpm	2900 rpm
Weight (incl. cable)	14 kg	17 kg	20 kg
Motor protection	built in		
Electric cable	10 m		
Free passage	Ø 40 mm		
Discharge connection	Hose 2" Option: G2"		

\*) Built in float switch available as option.

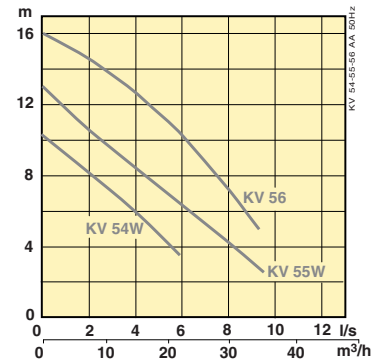
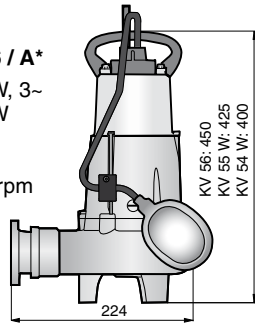



# PUMPEX TRANSPORTABLE SLUDGE PUMPS SK 65 - SK 155 FOR VERSATILE APPLICATIONS

**Pumpex submersible sludge pump SK 65 - SK 155** are suitable for pumping sludge and water mixed with solid. The robust cast iron design provides a sturdy pump for rough conditions. The pump runs at any water level without overloading the motor.

## **Trouble free and safe handling**

Pumpex sludge pump SK is a portable pump and features a sturdy stainless steel handle and a robust ductile iron stand. It can easily be lifted and moved to where it is needed without suction hoses or any concern about suction lifts. This makes installation and operation easy and safe.

## **Non overloading performance**

All SK sludge pumps can operate over the entire performance curve without overloading the motor.

## **Dry running capability**

A closed cooling system enables the Pumpex SK 83-155 to run dry, with no damage to the mechanical seals or the motor. Pumpex SK 65-80 needs to be submerged to half stator for continuous duty at max power.

## **Easy service and maintenance**

Modular design through the complete range with interchangeable spare parts makes maintenance and service easier. The sealed cable entry is easy to access and the hydraulic parts, such as impeller, seal cartridge and volute are easy to replace.

## **Solids handling capability**

The SK sludge pumps are fitted with free flow vortex impeller and pump housing that provides excellent non clogging performance.

## **High flexibility**

The pump can operate in any position, vertical or horizontal.



### **High reliability**

Pumpex SK 83-155 have cartridge seal unit with double mechanical seals, cooled by the closed cooling system, (silicon carbide on silicon carbide in the primary seal) for long life even under the most demanding operating conditions.

Pumpex SK 65-80 have double mechanical seals in oil bath with individual primary and secondary seals.

Rigid stainless steel shaft combined with double row angular contact ball bearings provide vibration-free operation and long pump life.

### **Explosion proof option**

All SK sludge pumps are available in explosion proof versions EExd IIB T4 and ATEX.

### **Environmentally safe**

The oil housing on the SK 65-80 is filled with environmentally safe white oil. The oil housing on the SK 83-155 is filled with environmentally safe glycol coolant.

Environmental friendly protection coatings are used on all the surfaces.

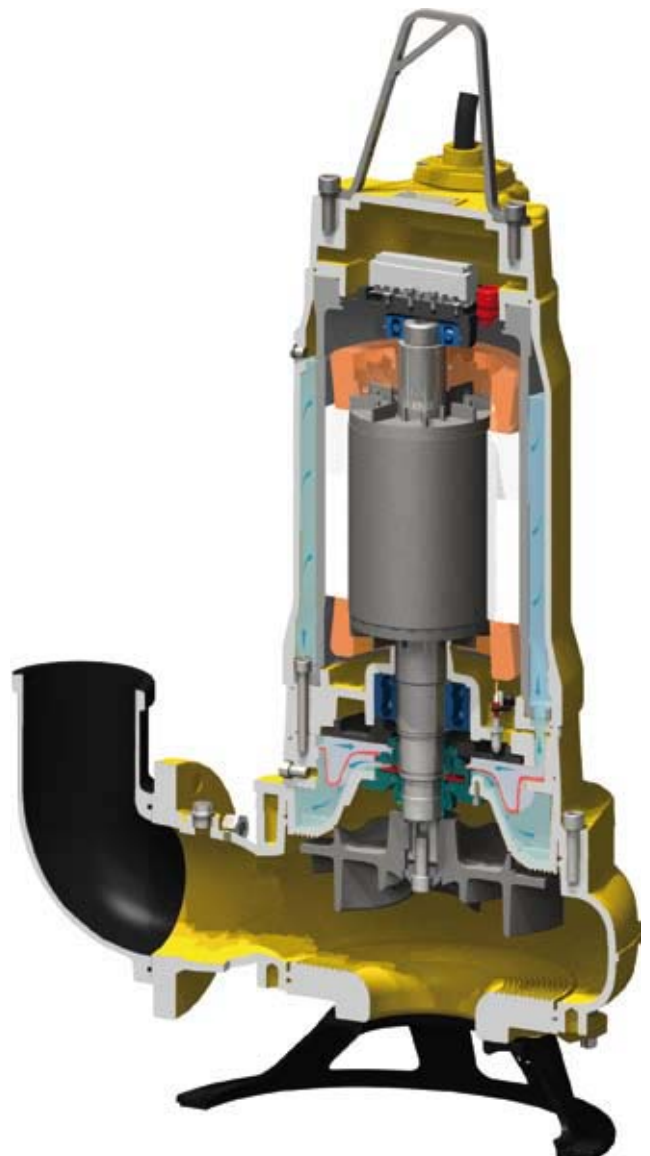

## PUMPEX SK 65

Pump Types	SK 65H-1.7	SK 65H-3
Motor rating $P_2$	1.7 kW, 3~	3.0 kW, 3~
Max. power input $P_1$	2.31 kW	3.74 kW
Voltage (V)	230/400/500	230/400/500
Full load (A)	6.9 / 4 / 3.18	10.8 / 6.2 / 4.98
Speed	2800 rpm	2835 rpm
Weight (incl. cable)	41 kg	48 kg
Motor protection	thermal overload sensors	
Electric cable	20 m	
Free passage	40 mm	
Discharge connection	hose 3" ,G 3" flanged DN 65	

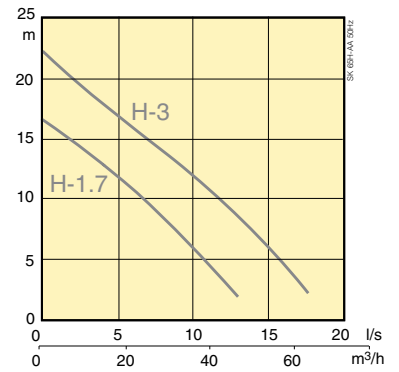
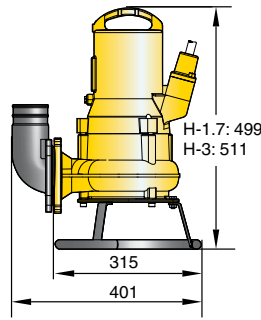

## PUMPEX SK 80

Pump Types	SK 80N-1.3	SK 80N-2.2
Motor rating $P_2$	1.3 kW, 3~	2.2 kW, 3~
Max. power input $P_1$	1.93 kW	2.88 kW
Voltage (V)	230/400/500	230/400/500
Full load (A)	6.26 / 3.6 / 2.8	8.96 / 5.2 / 4.12
Speed	1330 rpm	1380 rpm
Weight (incl. cable)	47 kg	47 kg
Motor protection	thermal overload sensors	
Electric cable	20 m	
Free passage	60 mm	
Discharge connection	hose 3" ,G 3" flanged DN 80	

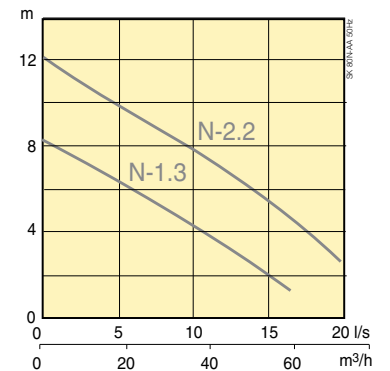
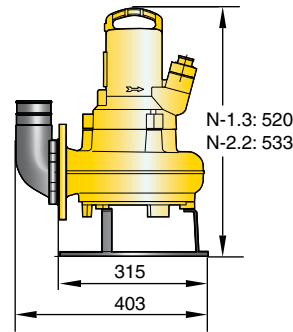

## PUMPEX SK 83

Pump Types	SK 83H-5.5	SK 83H-7	SK 83H-11
Motor rating $P_2$	5.5 kW, 3~	7.0 kW, 3~	11.0, 3~
Max. power input $P_1$	6.49 kW	8.37 kW	13.3
Voltage (V)	230/400/500	230/400/500	230/400/500
Full load (A)	18.1/10.4/8.31	23.7/13.6/10.9	38.4/22.1/17.7
Speed	2885 rpm	2875 rpm	2900 rpm
Weight (incl. cable)	153 kg	153 kg	165 kg
Motor protection	thermal overload sensors		
Electric cable	20 m		
Free passage	65 mm		
Discharge connection	hose 3" ,G3" (H-5.5) hose 4" ,G 4" (H-7, H-11) flanged DN 80		

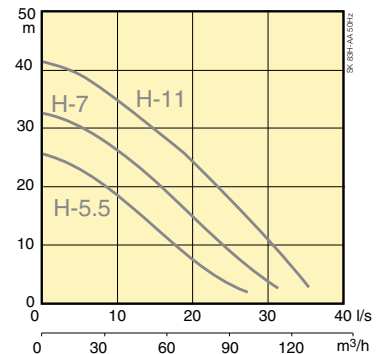
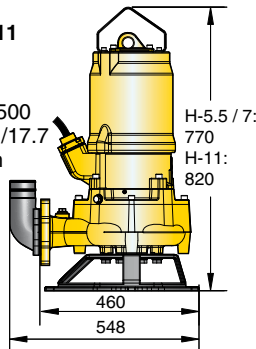

## PUMPEX SK 101

Pump Types	SK 101N-3
Motor rating $P_2$	3.0 kW, 3~
Max. power input $P_1$	3.95 kW
Voltage (V)	230 / 400 / 500
Full load (A)	12.2 / 7 / 5.6
Speed	1370 rpm
Weight (incl. cable)	111 kg
Motor protection	thermal overload sensors
Electric cable	20 m
Free passage	100 mm
Discharge connection	hose 4" ,G 4" flanged DN 100

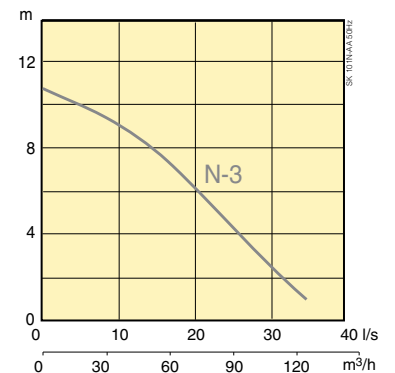
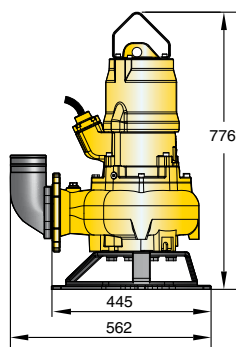

## PUMPEX SK 103

Pump Types	SK 103N-6	SK 103N-9
Motor rating $P_2$	6.0 kW, 3~	9.0 kW, 3~
Max. power input $P_1$	7.22 kW	10.8 kW, 3~
Voltage (V)	230/400/500	230/400/500
Full load (A)	21.8/12.5/10	33.7/19.4/15.5
Speed	1430 rpm	1425 rpm
Weight (incl. cable)	147 kg	157 kg
Motor protection	thermal overload sensors	
Electric cable	20 m	
Free passage	100 mm	
Discharge connection	hose 4" ,G 4" flanged DN 100	

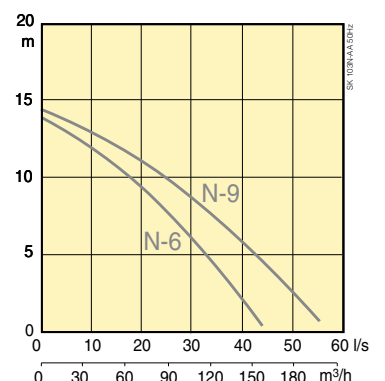
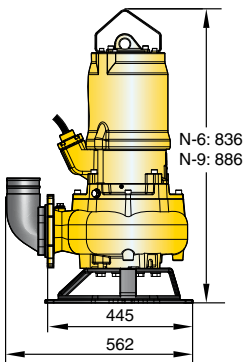



## PUMPEX SK 105H

Pump Types	SK 105H-20	SK 105H-25
Motor rating $P_2$	20.0 kW, 3~	25.0 kW, 3~
Max. power input $P_1$	22.1 kW	27.5 kW, 3~
Voltage (V)	230/400/500	230/400/500
Full load (A)	64.4/37/29.6	81.9/47.1/37.7
Speed	2945 rpm	2950 rpm
Weight (incl. cable)	286 kg	291 kg
Motor protection	thermal overload sensors	
Electric cable	20 m	
Free passage	64 mm	
Discharge connection	hose 4" ,G 4" flanged DN 100 man hole version Hose 4":	

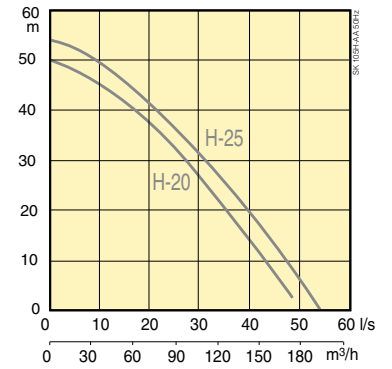
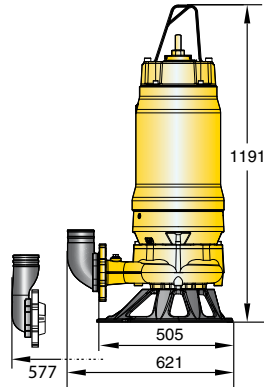

## PUMPEX SK 105N

Pump Types	SK 105N-16	SK 105N-22
Motor rating $P_2$	16.0 kW, 3~	22 kW, 3~
Max. power input $P_1$	17.8 kW	24.3 kW, 3~
Voltage (V)	230/400/500	230/400/500
Full load (A)	53.8/31/24.8	73.5/42.3/33.8
Speed	1460 rpm	1455 rpm
Weight (incl. cable)	346 kg	351 kg
Motor protection	thermal overload sensors	
Electric cable	20 m	
Free passage	80 mm	
Discharge connection	hose 4" ,G 4" flanged DN 100	

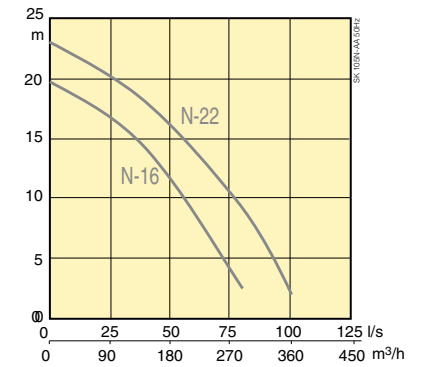
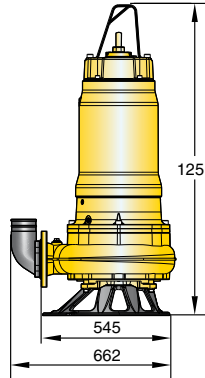

## PUMPEX SK 155

Pump Types	SK 155N-16	SK 155N-22
Motor rating $P_2$	16.0 kW, 3~	22.0 kW, 3~
Max. power input $P_1$	17.8 kW	24.3 kW, 3~
Voltage (V)	230/400/500	230/400/500
Full load (A)	53.8/31/24.8	73.5/42.3/33.8
Speed	1460 rpm	1455 rpm
Weight (incl. cable)	358 kg	363 kg
Motor protection	thermal overload sensors	
Electric cable	20 m	
Free passage	80 mm	
Discharge connection	hose 6" ,G 6" flanged DN 150	

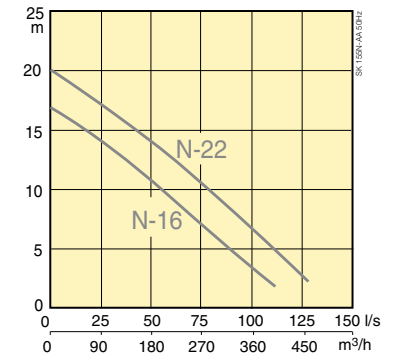
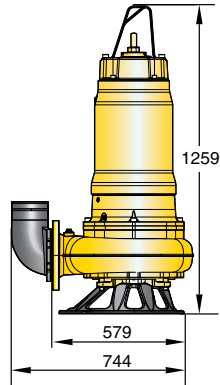

# OPTIONS AND ACCESSORIES



## Pump with built in float switch

P 601 110/230V, P 801 and SP 10 230V single phase as well as P 601 - P 801, SP 14 - SP 84 230/400V three phase are available with built in float switch when automatic start and stop is required.

A typical installation for automatic level control is in narrow sumps where the level of the sump is changing quickly.

## Starter box with float switch

When automatic start and stop operation is required this can be provided with a separate starter box or with a float switch built-in to the top of the pump.



## Starter box DOL/Star-Delta start

Pumpex supplies control panels for all kind of operations, as per international standard or specially designed to meet various local requirements and specifications. If a start and stop level is required float switches can be added to the boxes.

For more detailed information contact Pumpex.



## Electronic motor supervision

FSV 82, electronic motor protector. The motor protector prevents the pump from starting in the wrong direction of rotation. This protection device will also trip the pump in event of phase failure.

The FSV 82 features protection against automatic restart in event that the pump has tripped due to over heating.

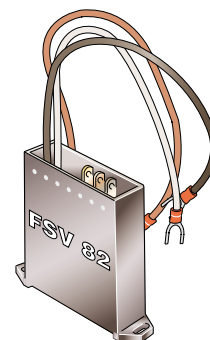

## SoftDrive™

SoftDrive™ is available built in on P 2001, P 3001 and PX 12. The Pumpex SoftDrive™ concept reduces starting current dramatically, providing a smooth operation for both the power net and pump equipment. Eliminates water hammering effects when the pump is stopped, allowing the pump to smoothly ramp down. Intelligent protection built into the pump, ensuring correct impeller rotation, motor protection and main power check at start up.





### Surface protection coating

For improved corrosion resistance. Pumpex offers a special surface protection with an extra layer of Pumpex environmental friendly 2-component epoxy coating on all casted parts.

For extreme conditions zinc anodes can be added to the 2-component epoxy coating.

---

### ZincPro™

Pumpex ZincPro™, a zinc protection system which can be used on all Pumpex submersible dewatering pumps, an easy way to extend the service life of pumps in salty water. Mounting sacrificing anodes of zinc to the pump body is a well proven method to reduce galvanic corrosion of aluminium castings when used in salty water. The method has been used for many years not only for submersible pumps but also to protect other machines such as outboard motors for leisure boats.



### Polyurethane

Pumpex offers Enduro Lining™, a solution where the diffusers and wear discs are coated with polyurethane.

Pumpex impellers are designed with a full upper shroud, which improves the wear resistance of the impeller and eliminates the need of polyurethane on the oil casing cover.

Polyurethane coated wear parts are mainly used in extremely abrasive applications such as mining.



---

### Stainless steel impellers

Pumpex also offers stainless steel impellers for SP pumps and a selected range of P, PC and PX pumps.







### Series connection

Series connections are available for all drainage pumps. The series connections have a center inlet for hose connection.

### Bottom suction adapter

On pumps types P 601, P 801 and P 1001 the standard bottom plate may be replaced by a bottom suction adapter. A basement floor or a tank can be pumped practically dry with this adapter

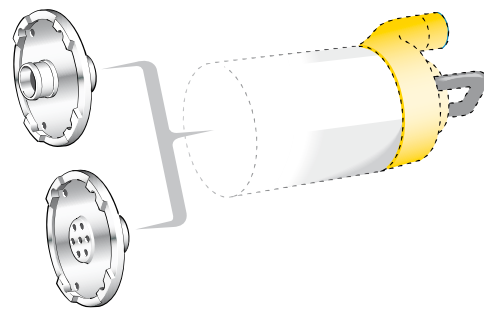

### PumpFloater™

Pumpex PumpFloater offers a modular system and cover pumps from 18 to 600 kg.

The PumpFloater is easy to use and build to any of Pumpex dewatering pumps. Other pump types may be used after checking the lifting capacity.

The flexible design makes it easy to simply add on another floatation module to increase the floating capacity.

The length of the 2 part lifting chain is easily adjusted for the pump to be installed in the water correctly.

### Hose, jointing pipe, clamp

Flexible reinforced discharge hose.

Available with inner diameter 1", 1 1/2", 2", 2 1/2", 3", 4", 6", 8".

Hose clamp and jointing pipe for flexible hose are available with same diameter..

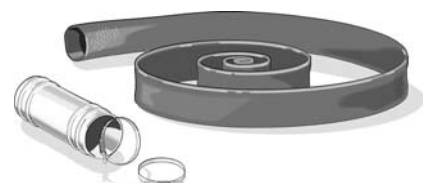



### Discharge connections

Pumpex drainage pumps can be equipped with a variety of discharge types. A threaded discharge connection can be used with a storz aluminium coupling for fast connection of the delivery hose.

The couplings can be supplied in the sizes: 2" (C), 3" (B), 4" (A), 6" (F)

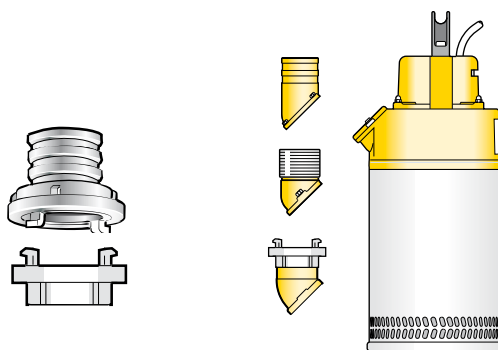

### Emergency kit

Pumpex emergency kit including pump, discharge connection, hose, hose clamps, lift-ing rope and extra accessory for low level pumping. The complete kit is lifted of a truck and brought to where it is needed. For emergency situations all equipment are on site for a fast, easy and safe installation. When pumping is ended it is easy to put parts back in the support case and bring it back to the truck or to the next site.





**Our products are being exported to more than  
70 countries, all over the world.**

The manufacturer reserves the right to alter performance, specifications or design without notice.  
P/SP/SK.GB50.0912 © Copyright (2009) Pumpex

**WWW.PUMPEX.COM**

**PUMPEX SALES**

P.O. Box 5207  
Rökerigatan 20  
SE-121 18 JOHANNESHOV  
Sweden

Tel: +46 10 47 47 225  
Fax: +46 8 659 33 14  
E-mail: [info@pumpex.com](mailto:info@pumpex.com)

**PUMPEX PRODUCTION**

Åsgatan 3  
SE-914 32 NORDMALING  
Sweden

Tel: +46 10 47 47 230  
Fax: +46 930 395 19  
E-mail: [info@pumpex.com](mailto:info@pumpex.com)

