

# NASH

A Gardner Denver Product

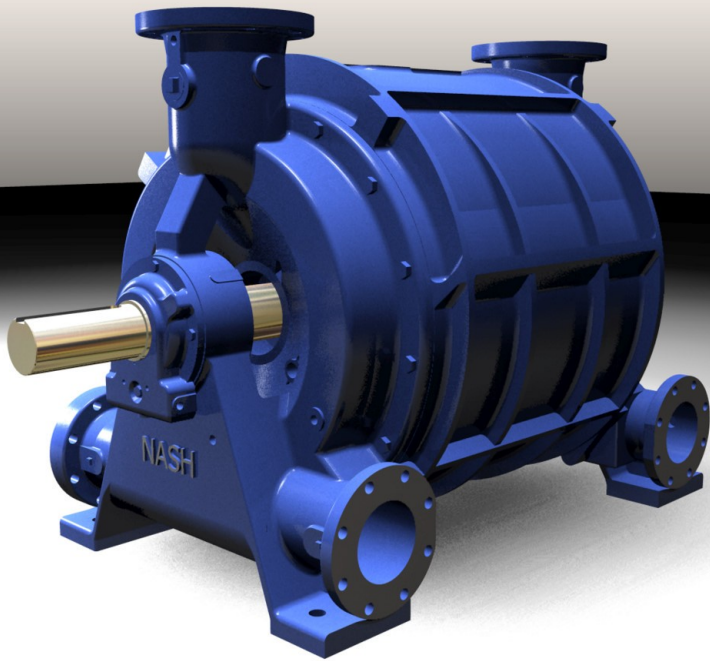

Gardner Denver NASH Liquid Ring Vacuum Pumps and Compressors have been 100% Locally manufactured by Vac-Cent Services since 1987.

Vac-Cent Services offer the entire Gardner Denver NASH vacuum pumps and Compressors in complete pumpsets and various materials.

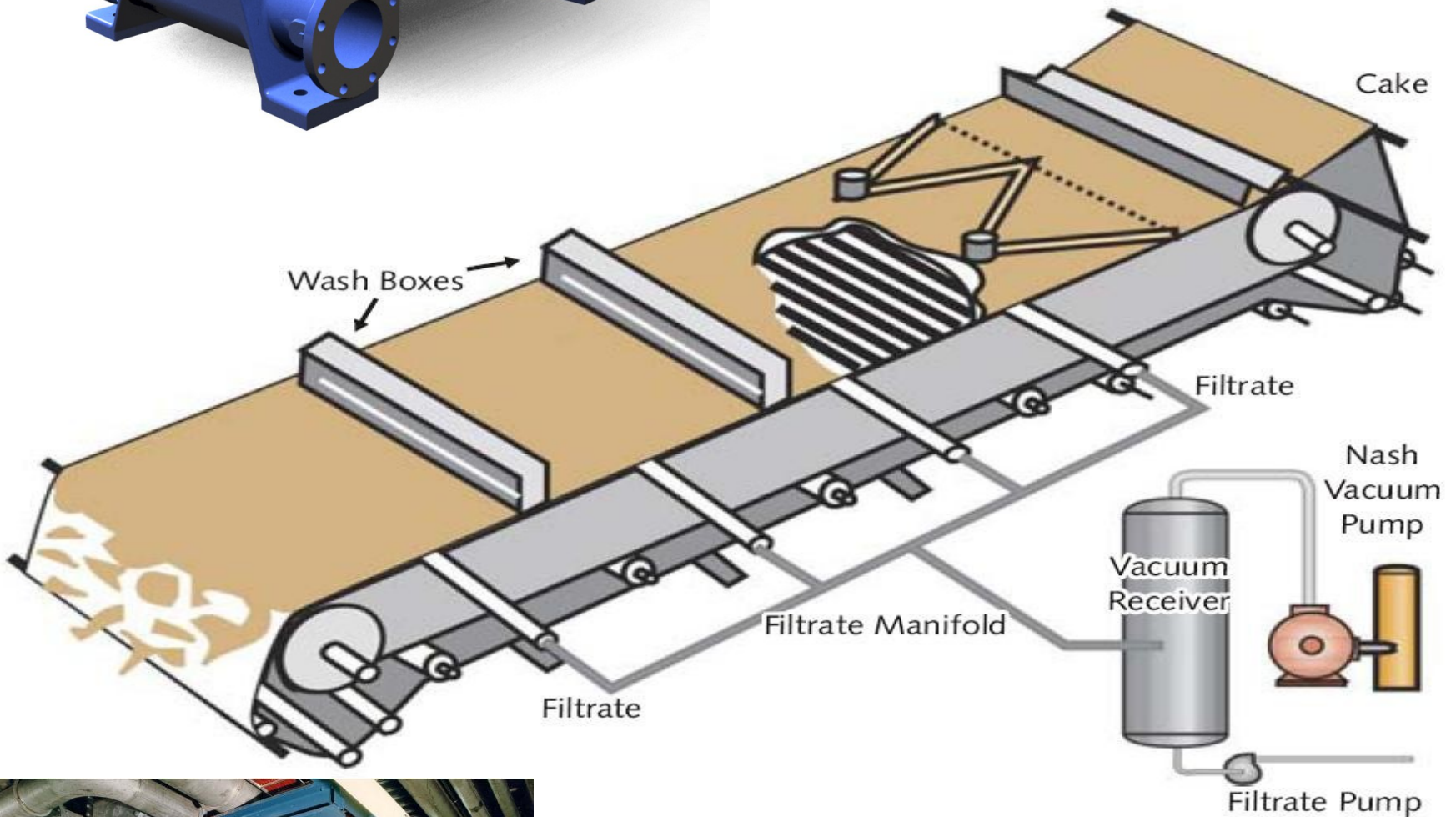

Gardner Denver NASH Liquid Ring Vacuum Pumps are built tough for the Mining ; Pulp & Paper ; Sugar and General industries and operate side-by-side with locally produced LiqEvac Process extraction pumps



SABS  
ISO 9001

[www.vaccent.co.za](http://www.vaccent.co.za) **Vac-Cent Services (Pty) Ltd.** 0861 VACUUM

Wadeville 124 Snapper rd, Wadeville // (T) +27 11 827 1536 // (F) +27 11 827 3590 // [faan@vaccent.co.za](mailto:faan@vaccent.co.za)  
Durban 6 Joseph Ave, Glen Anil // (T) +27 31 572 4495 // (F) +27 31 572 4535 // [nelson@vaccent.co.za](mailto:nelson@vaccent.co.za)



# LiqEvac Process Extraction pumps for Pre-Separators and Filtrate Receivers.

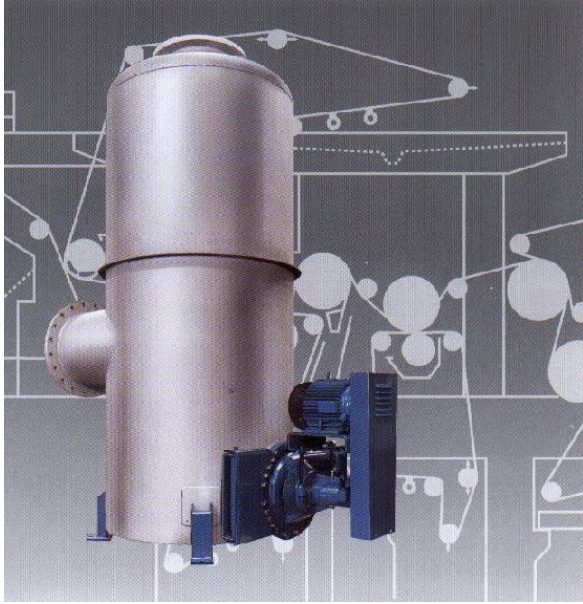

**LiqEvac** filtrate pumps are manufactured 100% in South Africa and are compatible with current models in the field.

They are available in all SG Iron, all 316 Stainless steel wetted ends and combinations of SG Iron and Stainless steel.

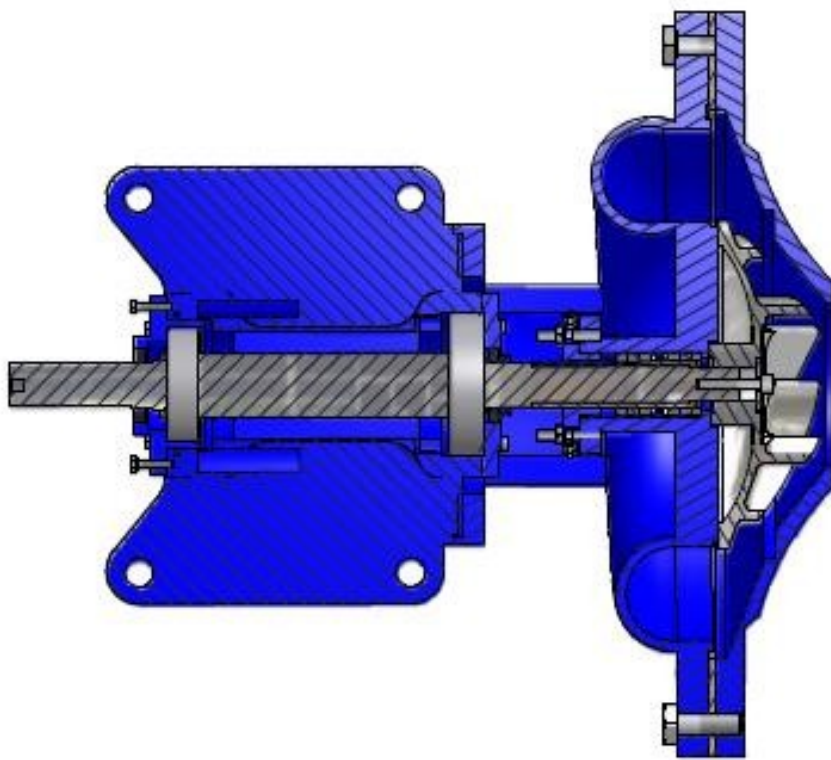

**There are two sizes available.**

- The **LiqEvac 2x9** with a maximum flow of 60 m<sup>3</sup>/hr or 1000 L/min ranging from 100 kPaG to 300 kPaG pressure.
- The **LiqEvac 4x9** with a maximum flow of 225 m<sup>3</sup>/hr or 3750 L/min ranging from 75 kPaG to 310 kPaG pressure.



**SABS**  
ISO 9001

[www.vaccen.co.za](http://www.vaccen.co.za) **Vac-Cent Services (Pty) Ltd.** 0861 VACUUM

Wadeville 124 Snapper rd, Wadeville // (T) +27 11 827 1536 // (F) +27 11 827 3590 // [faan@vaccen.co.za](mailto:faan@vaccen.co.za)  
Durban 6 Joseph Ave, Glen Anil // (T) +27 31 572 4495 // (F) +27 31 572 4535 // [nelson@vaccen.co.za](mailto:nelson@vaccen.co.za)

